



eco 0,1 Watt

MODELL	Classic 120	Classic 140	Classic 180	MODEL
Bestellnummer:	C 120	C 140	C 180	Order number:
Farbe	RAL 5002 RAL 9005	RAL 5002 RAL 9005	RAL 5002 RAL 9005	Color
MOTORDATEN:			MOTOR DATA:	
Volt	230 Volt, 50 Hz	230 Volt, 50 Hz	230 Volt, 50 Hz	Volt
kW	1,25	1,4	1,8	kW
Turbinen	2-stufig, Bypass	3-stufig, Bypass	3-stufig, Bypass	Turbines
LEISTUNGSDATEN:			PERFORMANCE DATA:	
Max. Unterdruck	2400 mm WS, 240 mbar	2980 mm WS, 298 mbar	3700 mm WS, 370 mbar	Max. low-pressure
Max. Luftleistung	190 m ³ /h	180 m ³ /h	190 m ³ /h	Max. airflow rate
Max. Air Watts	425	520	650	Max. air watts
Steuerspannung	12 Volt	12 Volt	12 Volt	Control voltage
Max. Rohrlänge	25 m	50 m	60 m	Max. pipe length
Schallpegel gemäß DIN EN ISO 3744	54 dBA	56 dBA	68 dBA	According to sound level DIN EN ISO 3744
ABMESSUNGEN:			MEASUREMENTS:	
Höhe	700 mm	700 mm	700 mm	Height
Durchmesser	306 mm	306 mm	306 mm	Diameter
Gewicht	14,2 kg	14,5 kg	14,9 kg	Weight
Schmutzbehälterinhalt	14 Liter	14 Liter	14 Liter	Dust bin capacity
FILTERDATEN:			FILTER DATA:	
Filter	Abwaschbarer Polyester-Filter washable polyester-filter < 0,2 µ	Abwaschbarer Polyester-Filter washable polyester-filter < 0,2 µ	Abwaschbarer Polyester-Filter washable polyester-filter < 0,2 µ	Filter
Filterfläche	0,7 m ²	0,7 m ²	0,7 m ²	Filter surface

- | | | |
|--------------|--------------|--------------|
| Standard | Standard | Standard |
| On / Off | On / Off | On / Off |
| PowerControl | PowerControl | PowerControl |

LIEFERUMFANG:

- 1 x Zentralstaubsauger, 1 x Wandhalterung,
- 1 x integrierter Abluftschalldämpfer, 2 x flexibler Anschluss, 4 x Schrauben, 4 x Dübel, 4 x Schellen,
- 1 x Außenabdeckung für Abluft, 1 x Installations- und Bedienungsanleitung (20 Seiten)



INCLUDES:

- 1 x central vacuum cleaner, 1 x wall bracket,
- 1 x integrated special muffler, 2 x flexible adapters,
- 4 x bolts, 4 x dowels, 4 x brackets, 1 x exhaust vent,
- 1 x installation and operating manual (20 pages)



KOHLESTAUBFILTER

170607

5 Stück Pack



CARBON DUST FILTER

170607

5 pieces per pack

**FILTEREINSATZ
FÜR MODELL CLASSIC**

170216



**FILTER INSERT
FOR MODEL CLASSIC**

170216

**KOHLEBÜRSTE
FÜR MODELL C 120 UND C 140**

170105



**CARBON BRUSHES
FOR MODEL C 120 AND C 140**

170105

**KOHLEBÜRSTE
FÜR MODELL C 180**

170117



**CARBON BRUSHES
FOR MODEL C 180**

170117

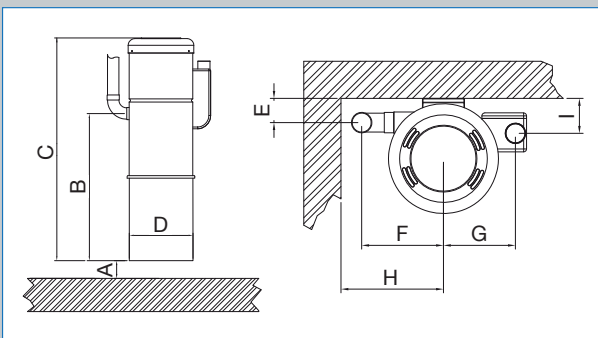

A	mind. 8 cm
B	37 cm
C	70 cm
D	28,7 cm
E	8,5 cm
F	24,5 cm
G	20 cm
H	34 cm
I	10 cm

Technische Daten Premium ein-motorig / Technical data Premium single-motor



eco 0,1 Watt

MODELL	Premium 120	Premium 140	Premium 180	MODEL
Bestellnummer:	P 120	P 140	P 180	Order number:
Farbe	RAL 5002 RAL 9005	RAL 5002 RAL 9005	RAL 5002 RAL 9005	Color
MOTORDATEN:			MOTOR DATA:	
Volt	230 Volt, 50 Hz	230 Volt, 50 Hz	230 Volt, 50 Hz	Volt
kW	1,25	1,4	1,8	kW
Turbinen	2-stufig, Bypass	3-stufig, Bypass	3-stufig, Bypass	Turbines
LEISTUNGSDATEN:			PERFORMANCE DATA:	
Max. Unterdruck	2400 mm WS, 240 mbar	2980 mm WS, 298 mbar	3700 mm WS, 370 mbar	Max. low-pressure
Max. Luftleistung	190 m ³ /h	180 m ³ /h	190 m ³ /h	Max. airflow rate
Max. Air Watts	445	520	650	Max. air watts
Steuerspannung	12 Volt	12 Volt	12 Volt	Control voltage
Max. Rohrlänge	25 m	50 m	60 m	Max. pipe length
Schallpegel gemäß DIN EN ISO 3744	54 dBA	54 dBA	68 dBA	According to sound level DIN EN ISO 3744
ABMESSUNGEN:			MEASUREMENTS:	
Höhe	1005 mm	1005 mm	1005 mm	Height
Durchmesser	306 mm	306 mm	306 mm	Diameter
Gewicht	16,8 kg	16,8 kg	16,8 kg	Weight
Schmutzbehälterinhalt	22 Liter	22 Liter	22 Liter	Dust bin capacity
FILTERDATEN:			FILTER DATA:	
Filter	Abwaschbarer Polyester-Filter washable polyester-filter < 0,2 µ	Abwaschbarer Polyester-Filter washable polyester-filter < 0,2 µ	Abwaschbarer Polyester-Filter washable polyester-filter < 0,2 µ	Filter
Filterfläche	1,37 m ²	1,37 m ²	1,37 m ²	Filter surface

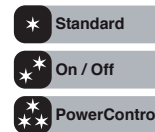
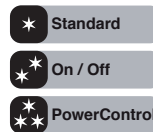
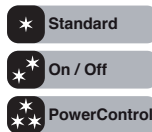

LIEFERUMFANG:

- 1 x Zentralstaubsauger, 1 x Wandhalterung,
- 1 x integrierter Abluftschalldämpfer,
- 2 x flexibler Anschluss, 4 x Schrauben,
- 4 x Dübel, 4 x Schellen, 1 x Außenabdeckung für Abluft,
- 3 x Staubbeutel mit Maximizer,
- 1 x Installations- und Bedienungsanleitung (20 Seiten)



INCLUDES:

- 1 x central vacuum cleaner, 1 x wall bracket,
- 1 x integrated special muffler, 2 x flexible adapters,
- 4 x bolts, 4 x dowels, 4 x brackets, 1 x exhaust vent,
- 3 x dust bags with maximizer,
- 1 x installation and operating manual (20 pages)



KOHLESTAUBFILTER

170607

5 Stück Pack



CARBON DUST FILTER

170607

5 pieces per pack

FILTEREINSATZ

FÜR MODELLE P 120, P 140 UND P 180

170209



FILTER INSERT

FOR MODELS P 120, P 140 AND P 180

170209

KOHLEBÜRSTE

FÜR MODELL P 120 UND P 140

170105



CARBON BRUSHES

FOR MODEL P 120 AND P 140

170105

KOHLEBÜRSTE

FÜR MODELL P 180

170117



CARBON BRUSHES

FOR MODEL P 180

170117

STAUBBEUTEL

MIT MAXIMIZER

170404

10 Stück Pack



DUST BAG

WITH MAXIMIZER

170404

10 pieces per pack

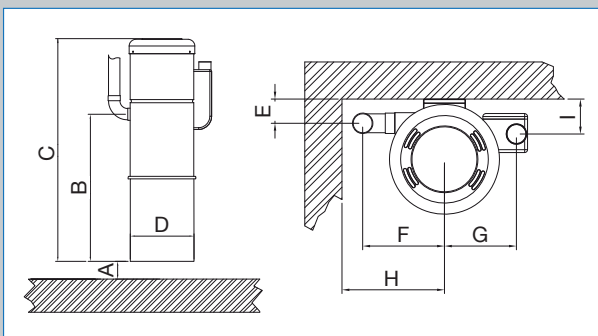

A	mind. 8 cm
B	66 cm
C	100,5 cm
D	28,7 cm
E	8,5 cm
F	24,5 cm
G	20 cm
H	34 cm
I	10 cm